

PAPER • OPEN ACCESS

Modeling the deformation behavior of polymer sandwich structures with inhomogeneous core

To cite this article: Laszlo Takacs and Ferenc Szabó 2020 *IOP Conf. Ser.: Mater. Sci. Eng.* **903** 012024

View the [article online](#) for updates and enhancements.

Modeling the deformation behavior of polymer sandwich structures with inhomogeneous core

Laszlo Takacs^{1,2}, Ferenc Szabó¹

¹ Department of Polymer Engineering, Faculty of Mechanical Engineering, Budapest University of Technology and Economics, H-1111 Budapest, Műegyetem rkp. 3., Hungary

² eCon Engineering Kft., H-1116 Budapest, Kondorosi út 3., Hungary

E-mail: szabof@pt.bme.hu

Abstract. Polymer sandwich structures become widely used in the transportation industry due to their high bending stiffness and strength combined with low weight. In the conceptual design phase, it is essential to model the mechanical behavior of the sandwich properly in full-vehicle scale in order to analyze different design variants effectively. In this paper, a finite element modeling method is shown. The method is introduced on a sandwich structure with glass fiber reinforced, vinyl-ester matrix composite face-sheets and a PET foam as core material with an inhomogeneous structure. To model the sandwich panel with layered shells, where the core material is a single layer, equivalent stiffness constants of the inhomogeneous core are needed. To determine these constants, a detailed finite element model was created and virtual tensile and shear tests were performed. On the other hand, an analytical method was also shown. By applying the Voigt- and Reuss-rule on the inhomogeneous core, the needed stiffness constants can also be determined properly. Results of the two methods were compared and they showed a good correlation. Validation of the model was performed via comparing the results of the 4-point bending experimental tests and the simulation results.

1. Introduction

Composite materials are increasingly present in the industry [1]. Polymer sandwich structures with composite face-sheets and foam core are widely used not only in aerospace but in automotive, autobus, marine and construction engineering as well. The main reasons are their high bending stiffness and strength combined with low weight. Therefore, extensive studies have been conducted on sandwich structures due to their significance in industrial applications. Although a comprehensive review of current trends in research and applications of sandwich structures was accomplished by Birman and Kardomateas [2] in 2018, here, some of the papers in this field are reviewed briefly. Different case studies have been published from automobile industry with the aim of weight reduction by using sandwich panels in the whole body, the floor panel or the luggage panel [3-5]. However, polymer sandwich structures are present in the autobus, marine and construction engineering as well [6-8]. Almost all the applications use thermoset polymers but beside the dominance of thermosets, thermoplastic core materials are strongly developed to take the advantages of thermoforming and recycling. The aim of their technology process development is cost efficiency [9].

To make the design process of sandwich structures effective it is essential to model the mechanical behavior accurately. Many researches have been published using numerical modeling and also experimental tests [10,11]. The main micromechanical methods of the modeling of sandwich structures



Content from this work may be used under the terms of the [Creative Commons Attribution 3.0 licence](https://creativecommons.org/licenses/by/3.0/). Any further distribution of this work must maintain attribution to the author(s) and the title of the work, journal citation and DOI.

are classified on the basis of whether they are modeled as an equivalent single layer, or as multiple layers. A more detailed modeling method is to use 3D finite elements. Ivanez et al. [12] analyzed the dynamic flexural behavior of a sandwich plate with a three-point bending test. They haven't used a layered shell model but a 3D-model instead with a proper damage-model of the core material as well. It was concluded that the compressive strength of the core material affects the failure of the sandwich more than the tensile strength of the composite face-sheets. Manalo et al. [13] investigated strength and failure modes of a polymer composite sandwich beam with 4-point bending in edgewise and flatwise position. Here, also a 3D model was used in the FEM simulation. The edgewise position showed stiffer behavior as expected, the failure mode was the progressive failure of the face-sheet, while in flatwise position, it was the shear failure and debonding of the core. Awad et al. [14] tested a newly developed GFRP sandwich panel with point load. A crushable foam model and Hashin failure criteria were used in the finite element analysis. Polymer sandwich panels with composite face-sheets and foam cores were investigated under impact loading by Long et al. [15]. Drop-tests were performed with different impact energy. Foam density and stacking sequence of the composite skins were varied. A new user-defined material was developed in Abaqus in order to model the sandwich failure more effective. Delamination, fracture and foam crush regions were analyzed to better understanding of the strength of such structures.

Our goal is to develop a finite element modeling method of sandwich panels with inhomogeneous core material that can be effectively used to model the deformation behavior of a structure even in full-vehicle scale, where the sandwich is modeled as layered shells. If the core is modeled as a single layer, equivalent stiffness constants are to be determined. Different methods are shown to extract these constants. Our results hold the promise of the development of a cost-effective sandwich modeling method that can be effectively used in the product development phase in the industry.

2. Materials and Experimental Tests

The material chosen to analyze the polymer composite sandwich structure is a glass fiber reinforced composite with vinylester matrix. This type of composite is typically used in the transportation industry. The fiber reinforcement is a multidirectional fabric with a stacking sequence of $0^\circ/45^\circ/90^\circ/-45^\circ$. The commercial name of the product is QE fabric as it is a so-called quadraxial fabric (Saertex GmbH, Germany). The specific weight is 1232 g/m^2 . The face-sheet of the tested sandwich structure has 3 layers of this fabric with the same orientation and with a symmetric lay-up. The thickness of the face-sheet is 2.5 mm. The matrix material of the composite is a vinylester, its commercial name is Distitron VE220 (Novia Kft., Hungary). It is recommended for resin-transfer molding or vacuum injection technology. The specimens were manufactured with vacuum injection technology, Butanox-M50 (methyl ethyl ketone peroxide, solution in dimethyl phthalate) was used as initiator and 0.2 wt% cobalt solution as activator. The curing time was 24 h in room temperature and then 3 h at 100°C .

The core material of the sandwich panel is a PET foam with the commercial name of Airex T90. It is a closed-cell foam with a density of 110 kg/m^3 . The type of the foam is named FlexiCut. It has a thickness of 25 mm and 1.2 mm thick cuts every 30 mm. Both sides have cuts, on one side the 85 % of the thickness is cut, on the other side the 20 % of the thickness. These cuts help the manufacturing, they transfer the resin and this structure allows the full impregnability of the sandwich. The structure of the foam is shown in Figure 1. These foams are likely to be used in the industry, they have good recyclability and flame-retardant properties can be also enhanced by different additives [16].

The mechanical tests were performed on a Zwick Z020 uniaxial testing machine on room temperature and with a relative humidity of $46\pm 2\%$. The Young's moduli and Poisson-ratios of the composite face-sheets were carried out with a displacement controlled tensile test following EN ISO 527-4 standard with the Type 3 specimen. The test speed was 2 mm/min. The test was performed until failure. The strain components were measured with two unidirectional strain gauges perpendicular to each other on one side of the specimen.

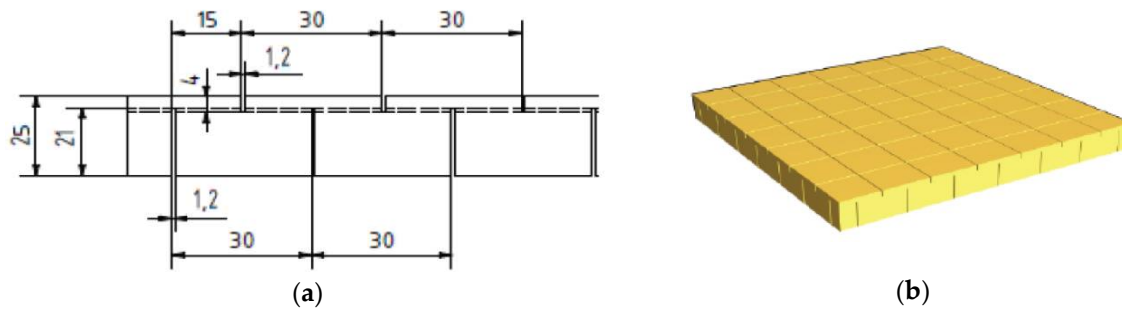

Figure 1. The structure of the FlexiCut foam: (a) sketch (b) 3D-view

The in-plane shear modulus was carried out with Iosipescu-test of a V-notched specimen following the standard ASTM-D5379 [17]. The test speed was 2 mm/min. To apply a clear shear loading on the specimen a special fixture is needed. During the test the specimen must remain plain and the edges parallel to each other. The sketch of the fixture can be seen on Figure 2 (a). To measure the shear deformation, strain gauges were used with a placement that can be seen on Figure 2 (b).

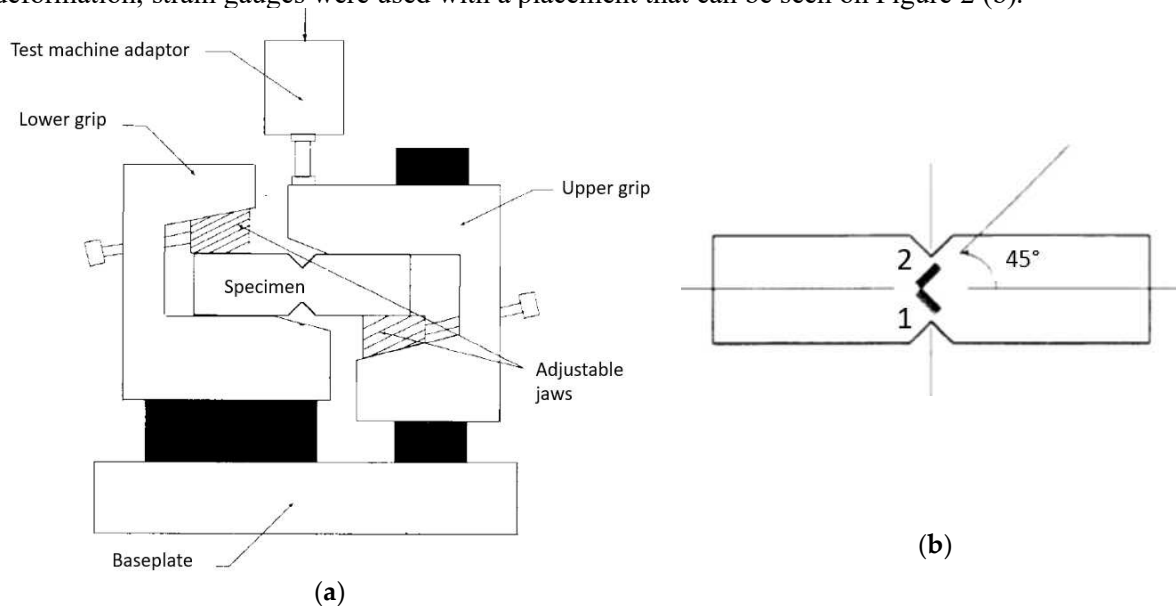

Figure 2. (a) The test fixture of the shear-test (b) Placement of the strain gauges

The shear deformation can be calculated as [17]:

$$\gamma_{xy} = \varepsilon_1 - \varepsilon_2 \quad (1)$$



Figure 3. 4-point bending of the sandwich beam

The stiffness parameters of the face-sheets can be determined with these tests but the core material cannot be directly tested. During manufacturing, the resin flows into the cuts of the used FlexiCut foam and that can significantly influence the stiffness of the core. This effect can be examined by the test of the complete sandwich. For the sandwich beams, a 4-point bending was performed following the standard ASTM-D7249. The test speed was 6 mm/min. The measured sandwich beam can be seen on Figure 3.

The aim of the study is to develop a method with which the deformation behavior of the sandwich structure can be effectively modeled in full structure scale in finite element analyses. When modeling a complete structure, e.g. vehicle body, layered shell elements are the most widely used instead of using solid elements. Solids allow deeper understanding of stress-state or even failure modes but the modeling and the calculation as well are more time-consuming so they are used generally in specimen scale.

In this study, first, we derived the stiffness parameters of the composite face-sheets from the tensile- and shear-tests, then we investigated the effect of the resin-walls in the core material on stiffness. For that, we used a mixed model using layered shells for face-sheets, solids for the core and shells for the resin-walls in the core. After that a method is introduced to derive the equivalent stiffness parameters of such a core material with the help of the Voigt- and Reuss-rules and the numerical shear-test of the core with its resin-walls. When having the equivalent stiffness constants, the modeling of the whole sandwich structure with a layered shell is possible. Results are validated with the mixed solid-shell models and the experimental tests.

3. Modeling Method

Modeling composites with layered shells is a widely used modeling technique. With this method, the layers are taken as homogeneous, anisotropic ones and the stiffness of the whole laminate is calculated with the classical laminate theory (CLT). Various kinds of commercial finite elements software are using this method as well. Quadrax fabrics are made by sewing unidirectional reinforcing layers together using thin polyester fibers, so the quadrax layer can be taken as an asymmetrical sub-laminate with four unidirectional reinforcing layers rotated relative to one another. We used an orthotropic material model and based on the structure of the reinforcing layer, moduli E_1 and E_2 are equal. These tensile moduli and the Poisson-ratio can be determined from the tensile test, shear-modulus can be expressed from the Iosipescu-test results the following way:

$$G_{12} = \frac{\tau_{12}}{\gamma_{12}} = \frac{F_{shear}}{A \gamma_{12}} \quad (2)$$

where F_{shear} is the shear force, A is the cross-sectional area and γ_{12} is the shear strain.

The deformation behavior of the composite face-sheet can be properly modeled using orthotropic material model with the above constants, but the modeling method of the core-material depends strongly on its structure. Vehicle chassis structures are commonly modeled with shell elements due to their shell-like geometrical build-up. Furthermore, modeling with shell elements requires less work capacity and means less computational time compared to using solid elements. Our aim is to characterize the mechanical behavior of the core-material and present a method with which the complete sandwich panel can be modeled as a shell.

The investigated core material is closed-cell PET foam which has thin grooves. These serve that the foam can be better formed in a 3D-shape mold and also helps the impregnation process as the resin passes through the grooves during injection. After manufacturing, thin resin walls are formed in the core which affect the mechanical behavior of the sandwich panel. In order to investigate the effect of this wall structure a solid-shell finite element model was built based on the ASTM D7249 measurement layout and specimen geometry. The average element size is 2 mm, face-sheets are modeled using shell elements with orthotropic material model, the foam with solid elements with isotropic material model and the resin walls with isotropic shells having common nodes with the solids of the foam. The elastic modulus of the foam is 110 MPa and the resin is 3412 MPa. These were determined via tensile tests. The structure of the model is shown in Figure 4.

We simulated the same four-point bending as the experiment. The contact surfaces of the supports and the load introductions were considered infinitely rigid and frictionless contact definitions were used. As a vertical displacement, 7 mm was applied.

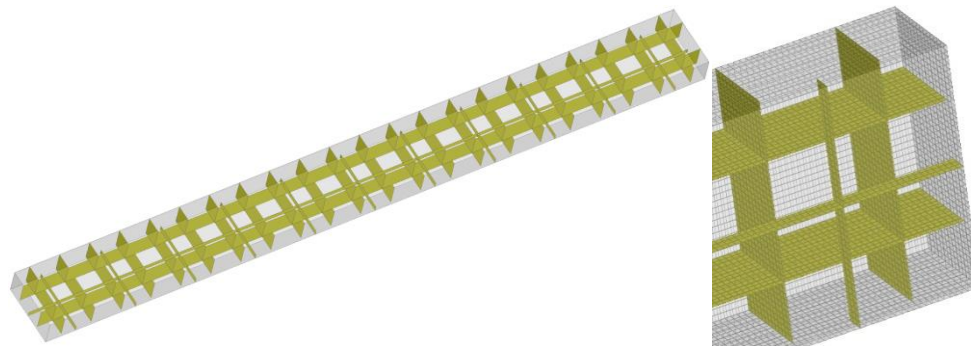

Figure 4. Finite element model of the sandwich core – resin walls with shell elements

A method is required to determine an equivalent modulus that can be used to characterize the resin impregnated foam. To determine this, we used the relationships of the micromechanics, respectively the rules of mixture. When applying the rules of mixture, the premise is that there are no cavities or foreign material in the composite and there is perfect adhesion between the components.

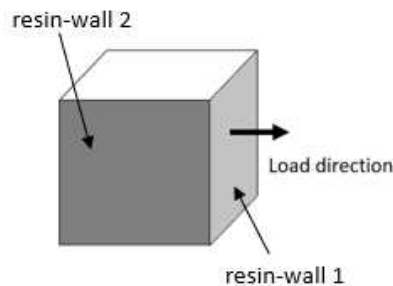

Figure 5. A “primitive cell” of the foam including resin walls

The equivalent modulus is deduced of a primitive cell of the core containing two resin walls, which is shown in Figure 5. The normal of resin-wall 1 is parallel to the load direction while the normal of resin-wall 2 is perpendicular to the load-direction. The direction of the resin walls is important in determining the equivalent modulus, but since a primitive cell is examined and the volume of the resin walls are the same, the equivalent modulus can be considered as a direction independent parameter.

If we first consider only the foam with resin-wall 2, the Voigt-rule [18] can be used to determine the E_{e1} equivalent modulus as follows:

$$E_{e1} = \Phi_1 E_r + (1 - \Phi_1) E_f, \quad (3)$$

where E_r is the elastic modulus of the resin, E_f is the elastic modulus of the foam and Φ_1 is the resin content of the primitive cell without the volume of resin-wall 1. Φ_1 can be derived from the volumetric ratio as:

$$\Phi_1 = \frac{V_{rw1}}{(V_{primitive\ cell} - V_{rw2})}, \quad (4)$$

where V_{rw1} is the volume of resin-wall 1 of the figure, V_{rw2} is the volume of resin-wall 2 of the figure, and $V_{primitive\ cell}$ is the volume of the entire primitive cell.

If we now consider resin-wall 2 also, then the Reuss-rule [19] can be used to determine the equivalent modulus of the complete primitive cell. The expression is as follows:

$$E_e = \left(\frac{\Phi_2}{E_r} + \frac{1 - \Phi_2}{E_{e1}} \right)^{-1} = \frac{E_r E_{e1}}{\Phi_2 E_{e1} + (1 - \Phi_2) E_r}. \quad (5)$$

where Φ_2 can be interpreted with the volumetric ratio as:

$$\Phi_2 = \frac{V_{rw2}}{V_{primitive\ cell}}, \quad (6)$$

Based on these, using the two simple relationships described above, the equivalent modulus of the heterogeneous sandwich core material can be determined.

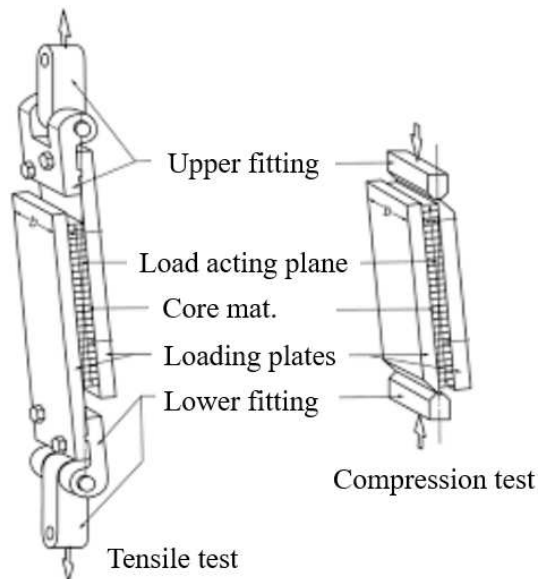

Figure 6. Shear test of sandwich core according to ASTM-C273

The sandwich panels are predominantly subjected to bending load, the bigger part of tension and compression is taken by the face-sheets, while the foam is subjected to considerable shear. Thus, an equivalent shear modulus is also required to model the heterogeneous core material of sandwich structures. Recommendations for this are given in ASTM C273, Figure 6 shows the standard measurement layout.

From the reaction force and the displacement, the shear modulus can be calculated in the following way:

$$G_e = \frac{S t}{L b} \quad (7)$$

where t is the thickness of the core, L and b are the length and width of the specimen. S can be calculated as follows:

$$S = \frac{F_{reaction}}{\Delta x} \quad (8)$$

where $F_{reaction}$ is the evaluated reaction force and Δx is the crosshead displacement, whereas in the virtual test it is the defined displacement.

4. Results and Discussion

Table 1 summarizes the orthotropic elastic constants of the quadrax fiber reinforced composite face-sheet obtained from the tensile- and the shear-test. Both the tensile and the shear tests were performed with 5 specimens. Average values and relative scatter are shown.

Table 1. Stiffness parameters of the glass fiber reinforced vinyl ester matrix composite face-sheet

Stiffness parameters of composite face-sheet	
E1 (MPa)	18051 ± 15%
E2 (MPa)	18051 ± 15%
ν_{12} (-)	0.298 ± 29%
G12 (MPa)	7035 ± 9%

After having the elastic constants of the face-sheet, the sandwich panel was analyzed. The 4-point bending test results of the detailed model show that neglecting the resin walls in the core, the stiffness would be underestimated by approximately 16%, as the reaction forces at 7 mm vertical displacement are 1181.5 N with and 1586.5 N without resin walls.

As the wall structure of the investigated foam is more complex in reality, we applied the procedure of rules of mixtures to the entire heterogeneous structure of the specimen. With a wall thickness of 1.2 mm, the calculation gives an equivalent modulus of 242.2 MPa

To test the accuracy and sensitivity of the procedure, a virtual tensile test was performed on the heterogeneous core material, without face-sheets, by fixing the nodes at one end and moving the nodes at the other end 10 mm longitudinally. With the calculations we investigated the effect of the thickness of the resin wall. By evaluating the longitudinal relative elongation (ε_y) and the reaction force (F_{reaction}), the equivalent elastic modulus can be determined as follows:

$$E_{e\text{FEM}} = \frac{F_{\text{reaction}}}{\varepsilon_y} \cdot \frac{A}{L} \quad (9)$$

The finite element simulations were performed at 0.7 mm, 1.2 mm and 1.5 mm resin wall thicknesses. The equivalent elastic modulus values derived from the simulations were then compared to the ones determined with the rule of mixtures.

The comparison is shown in Figure 7. The results obtained by the two methods are in good agreement with each other. With 0.7mm wall thickness, the match is perfect, for bigger wall thicknesses, the method minimally overestimates the modulus, for 1.5mm resin wall thickness the difference is 4%.

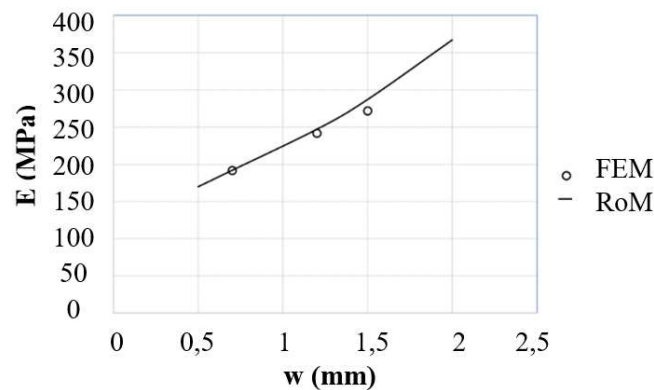

Figure 7. Equivalent elastic moduli carried out from FEM simulations and Rule of Mixture at different wall thicknesses

We performed a virtual test with the shear-measurement lay-up using the solid-shell model of the panel. The nodes of the upper sheet were fixed and the nodes of the lower sheet were moved by 20 mm.

The obtained equivalent shear modulus of the heterogeneous core is 74.6 MPa.

Beside the moduli, the Poisson-ratio is also to be mentioned. The bending behavior of the sandwich is hardly sensitive to the Poisson-ratio of the core. We investigate this with the virtual bending of a sandwich specimen modeled with shell elements. The core had an orthotropic material model with the moduli values obtained above. The Poisson-ratio was varied from 0.1 to 0.4 with a 0.05 step size. The evaluated reaction forces showed less than 0.5% difference between the two extreme cases. Based on this for further simulations we have used the Poisson-ratio of 0.35 which comes from the data sheet of the raw material.

Finally, the comparison of the 4-point bending results is summarized in Table 2.

Table 2. Comparison of the 4-point bending results

	F_{reaction} (N) @ 7 mm vertical deflection	difference to experiment	simulation time (s)
experimental test	1811	-	-
FEM model – detailed	1823	3.2%	17446
FEM model – layered shell	1881	3.7%	317

By having the equivalent engineering constants of the heterogeneous core, it is possible to model the complete sandwich panel with layered shell elements. We performed a standard 4-point bending with both the detailed model and the layered shell model. The test lay-up follows the standard ASTM-D7249.

The model with layered shells has the middle layer with a thickness of 25 mm and an orthotropic material model with the engineering constants obtained with the method described above. The average element size was 5 mm. The prescribed motion was 7 mm for both models. The reaction force was 1881.5 N for the layered shells and 1822.9 N for the solid-shell model. To compare, the average reaction force value of the tested specimens at 7 mm displacement was 1811.4 N. This means a 3.2% difference in comparison to the detailed model and 3.7% difference in comparison to the experiments. In terms of simulation time, we got a huge difference. The simulations were performed on a computer with an Intel Xeon CPU and 128 GB RAM. This means only a slight difference taking into account that using this method is much less time-consuming regarding the modeling complexity and also the simulation time. So, the method can be effectively used to model sandwich panels with heterogeneous core materials.

5. Conclusions

The aim of the study is to develop a method with which the deformation behavior of the sandwich structure can be effectively modeled with shell elements in finite element analyses. In this study, first, we derived the stiffness parameters of the composite face-sheets from the tensile- and shear-tests, then investigated the effect of the resin-walls in an inhomogeneous core material on stiffness. The 4-point bending tests of a detailed model show that neglecting the effect of these resin walls would underestimate the stiffness with almost 16%. Voigt- and Reuss-rules can be effectively used to determine the equivalent tensile moduli of such core materials. When having the equivalent stiffness constants, the modeling of the whole sandwich structure with a layered shell is possible. Results are validated with the mixed solid-shell models and the experimental tests. They show that a difference of less than 4% in comparison to the experimental test can speed up the simulation time with two orders of magnitude.

Acknowledgement

The project is funded by the National Research, Development and Innovation (NKFIH) Fund, Project title: “Production of polymer products by a short cycle time, automatized production technology for automotive applications, with exceptional focus on the complexity and recyclability of the composite parts”; The application ID number: NVKP_16-1-2016-0046. The developers are grateful for the support.

References

- [1] Mochane M.J. et al 2019 *Express Polymer Letters* **13** 159-198
- [2] Birman V.; Kardomateas, G.A. 2018 *Composites Part B: Engineering* **142** 221-240
- [3] Velea M.N. et al 2014 *Composite Structures* **111** 75-84
- [4] Hara, D.; Özgen, G.O. 2016 *Transportation Research Procedia* **14** 1013-1020
- [5] Alok Raj et al 2018 *IOP Conference Series: Materials Science and Engineering* **422** 012004
- [6] Wu H.C. et al 2003 *Composites Part B: Engineering* **34** 51-58.
- [7] Shen W. et al 2017 *Ocean Engineering* **144** 78-89
- [8] Kulpa M.; Siwowski T. 2019 *Composites Part B: Engineering* **167** 207-220
- [9] Sewell J. et al 2016 *Reinforced Plastics* **60** 146-150
- [10] Kovács L.; Romhány G. 2018 *Periodica Polytechnica Mechanical Engineering* **62** 158–164
- [11] Asadi A. et al 2018 *Express Polymer Letters* **12** 781-789
- [12] Ivañez I. et al 2010 *Composite Structures* **92** 2285-2291
- [13] Manalo A.C. et al 2010 *Composite Structures* **92** 984-995
- [14] Awad Z.K. et al 2012 *Engineering Structures* **41** 126-135
- [15] Long S. et al 2018 *Composite Structures* **197** 10-20
- [16] Szabó V.A.; Dogossy G. 2020 *Periodica Polytechnica Mechanical Engineering* **64** 81–87
- [17] ASTM-D5379 2019 *ASTM International*
- [18] Voigt W. 1889 *Wiedemann's Annalen der Physik und Chemie* **38** 573-587
- [19] Reuss A. 1929 *Zeitschrift für Angewandte Mathematik und Mechanik* **9** 49-58